



Access Security Solutions



TRIPOD TURNSTILE

Introduction

- Structure: The entire turnstile is made of 304 stainless steel sheet metal, rust proof, sturdy and durable,
- Dimensions: length 1200 x width 280 x height 980 (mm)
- Rod length: 500 (mm)
- Pass direction: one-directional or bidirectional
- Working environment: indoor and outdoor (preferably with a canopy)

Basic functions

- Automatic reset function
- Ultra high brightness traffic indication function
- Multiple travel mode functions
- Traffic request memory function
- Power off and automatically drop arm function
- Anti collision function
- Multiple control functions
- External buttons, remote controls, barcode scanners, IC or ID reader
- Anti tailgating function
- Remote control function
- The gate can be remotely controlled by connecting to an RS485 card or TCP to RS485 via a computer
- Automatic locking function: If the card swipe fails to pass within the specified time, the gate will be locked again to cancel the passage, with a time of 1-60 seconds.

Extend functions

- Traffic limit function
- Counting function: add a counter to count the number of entering & exiting
- Anti reverse passage function
- Illegal intrusion alarm

The color of cabinet is optional.

Application scenarios

- Offices: commercial buildings, government agencies, etc.
- Science and education: universities, research institutes, libraries, etc.
- Commercial service: supermarkets, shopping malls, hotels, clubs, banks, etc.
- Leisure & entertainment venues: parks, scenic spots, amusement parks, etc.
- Transportation: bus stations, train stations, subway stations, airports, etc.

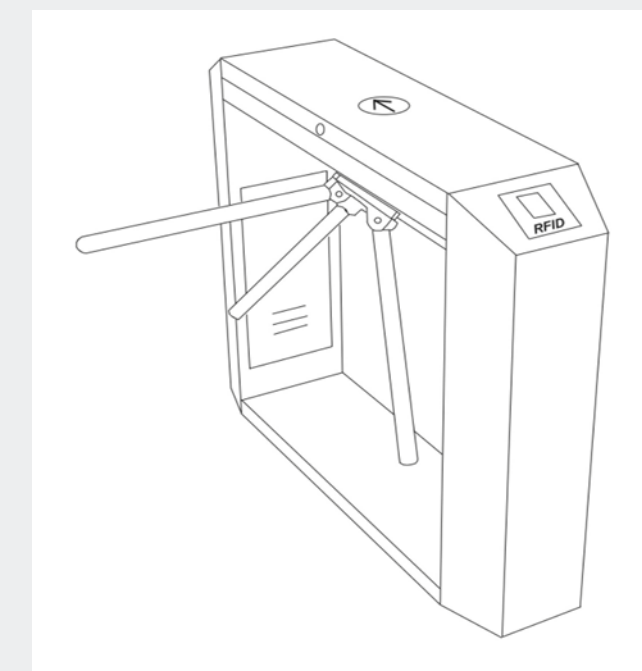

TRIPOD TURNSTILE

EN108

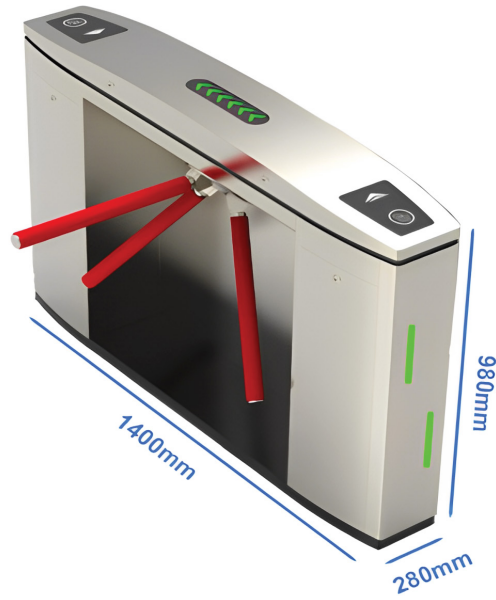

Access control

* RFID reader, Barcode scanner, Facial recognition, Fingerprint reader



Specifications

- | | |
|--------------------------------|-------------------------------|
| * Size: 1200x280x980mm | * Material: 1.2/1.0mm 304 SUS |
| * Pass Width: 550mm | * Pass rate: 30-35p/min |
| * Operating time: 0.2s | * Input: AC100-240V,50/60HZ |
| * Opening signal: Dry contact | * Working voltage: DC24V |
| * Mechanism: Pro solenoid lock | * MCBF: 5 million times |

EN111

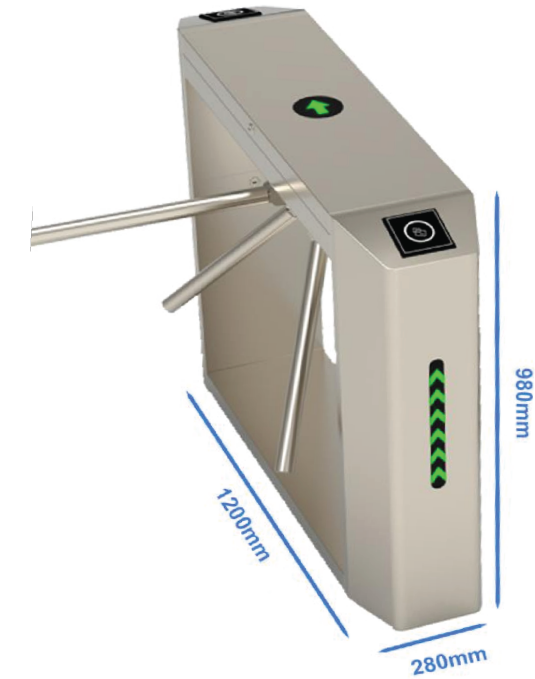

Access control

* RFID reader, Barcode scanner, Facial recognition, Fingerprint reader



Specifications

- | | |
|--------------------------------|-------------------------------|
| * Size: 1200x280x980mm | * Material: 1.2/1.0mm 304 SUS |
| * Pass Width: 550mm | * Pass rate: 30-35p/min |
| * Operating time: 0.2s | * Input: AC100-240V,50/60HZ |
| * Opening signal: Dry contact | * Working voltage: DC24V |
| * Mechanism: Pro solenoid lock | * MCBF: 5 million times |

TRIPOD TURNSTILE

EN112



Access control

* RFID reader, Barcode scanner, Facial recognition, Fingerprint reader



Specifications

- | | |
|--------------------------------|-------------------------------|
| * Size: 1200x280x980mm | * Material: 1.2/1.0mm 304 SUS |
| * Pass Width: 550mm | * Pass rate: 30-35p/min |
| * Operating time: 0.2s | * Input: AC100-240V,50/60HZ |
| * Opening signal: Dry contact | * Working voltage: DC24V |
| * Mechanism: Pro solenoid lock | * MCBF: 5 million times |

EN114



Access control

* RFID reader, Barcode scanner, Facial recognition, Fingerprint reader



Specifications

- | | |
|--------------------------------|-------------------------------|
| * Size: 1200x280x980mm | * Material: 1.2/1.0mm 304 SUS |
| * Pass Width: 550mm | * Pass rate: 30-35p/min |
| * Operating time: 0.2s | * Input: AC100-240V,50/60HZ |
| * Opening signal: Dry contact | * Working voltage: DC24V |
| * Mechanism: Pro solenoid lock | * MCBF: 5 million times |

TRIPOD TURNSTILE

EN115

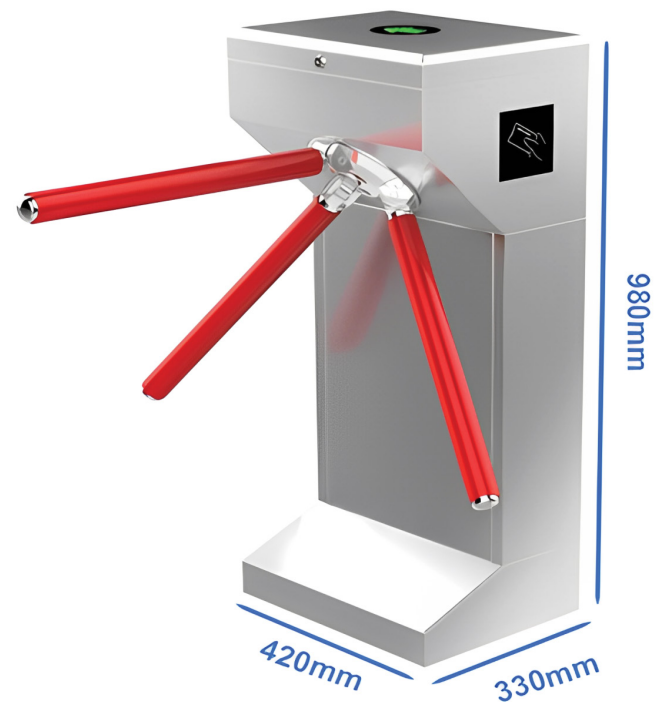

Access control

* RFID reader, Barcode scanner, Facial recognition, Fingerprint reader



Specifications

* Size: 1200x280x980mm	* Material: 1.2/1.0mm 304 SUS
* Pass Width: 550mm	* Pass rate: 30-35p/min
* Operating time: 0.2s	* Input: AC100-240V,50/60HZ
* Opening signal: Dry contact	* Working voltage: DC24V
* Mechanism: Pro solenoid lock	* MCBF: 5 million times

EN116

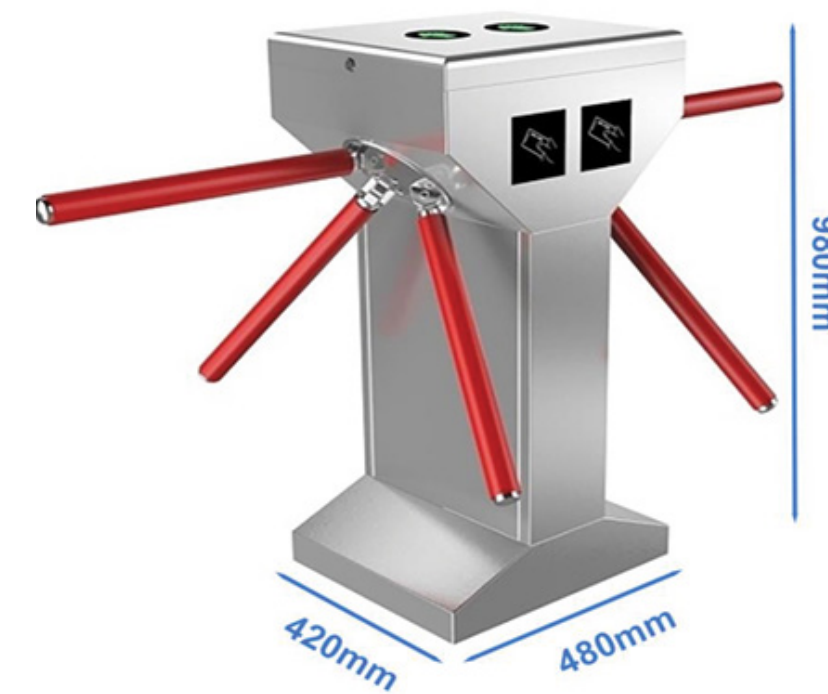

Access control

* RFID reader, Barcode scanner, Facial recognition, Fingerprint reader



Specifications

* Size: 1200x280x980mm	* Material: 1.2/1.0mm 304 SUS
* Pass Width: 550mm	* Pass rate: 30-35p/min
* Operating time: 0.2s	* Input: AC100-240V,50/60HZ
* Opening signal: Dry contact	* Working voltage: DC24V
* Mechanism: Pro solenoid lock	* MCBF: 5 million times

SWING GATE

Introduction

- Structure: The entire turnstile is made of 304 stainless steel sheet metal, rust proof, sturdy and durable.
- Drive motor: DC24V brushless motor
- Dimensions: length 1200 x width 180 x height 980 (mm) / customized size
- Pass width: 600-900 (mm), max can do 1800mm width for specific model.
- Pass direction: one-directional or bidirectional
- Working environment: indoor and outdoor (preferably with a canopy)

Basic functions

- Automatic reset function
- Ultra high brightness traffic indication function
- Multiple pass mode functions
- Traffic request memory function
- Power off and open automatically function
- Anti collision function
- Anti tailgating function
- Anti pinch function: Infrared/mechanical
- Multiple control functions
- External buttons, remote controls, barcode scanners, IC or ID reader
- Gate opening and closing speed adjustable
- Remote control function: The gate can be remotely controlled by connecting to an RS485 card or TCP to RS485 via a computer
- Automatic locking function: If the card swipe fails to pass within the specified time, the gate will be locked again to cancel the passage, with a time of 1-60 seconds

Extend functions

- Traffic limit function
 - Counting function: add a counter to count the number of entering & exiting
 - Anti reverse passage function
 - Illegal intrusion alarm
- The color of cabinet is optional.*

Application scenarios

- Offices: commercial buildings, government agencies, etc.
- Science and education: universities, research institutes, libraries, etc.
- Commercial service: supermarkets, shopping malls, hotels, clubs, banks, etc.
- Leisure & entertainment venues: parks, scenic spots, amusement parks, etc.
- Transportation: bus stations, train stations, subway stations, airports, etc.

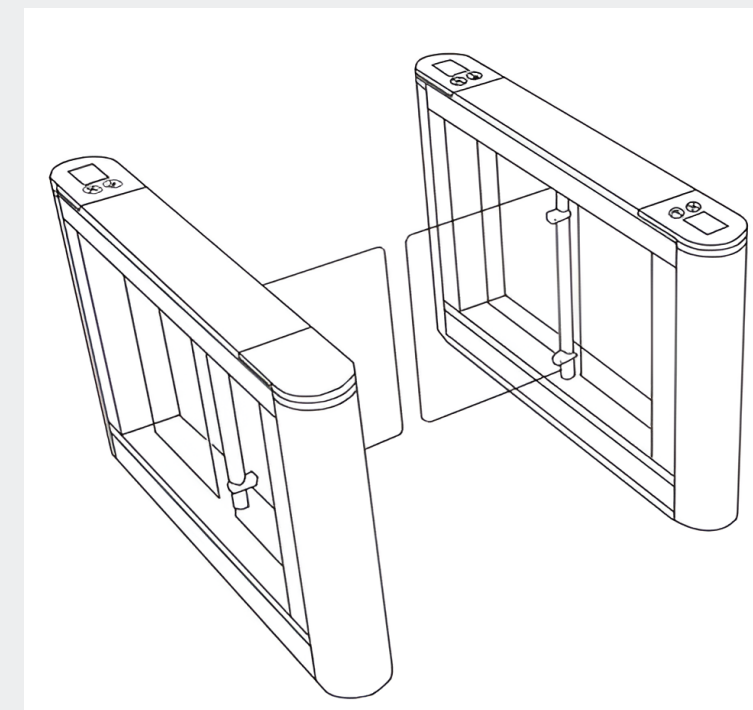

SWING GATE

EN04

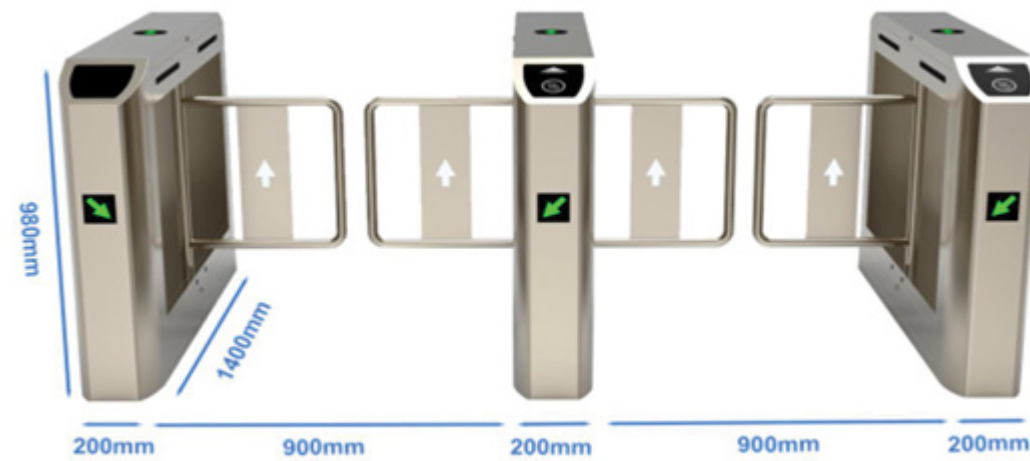

Access control

* RFID reader, Barcode scanner, Facial recognition, Fingerprint reader



Specifications

* Size: 1400x180x980mm	* Material: 1.5/1.2mm 304 SUS
* Pass Width: 600-900mm	* Pass rate: 30-35p/min
* Operating time: 0.2s	* Input: AC100-240V,50/60HZ
* Opening signal: Dry contact	* Working voltage: DC24V
* Drive unit: DC brushless motor	* MCBF: 5 million times

EN15

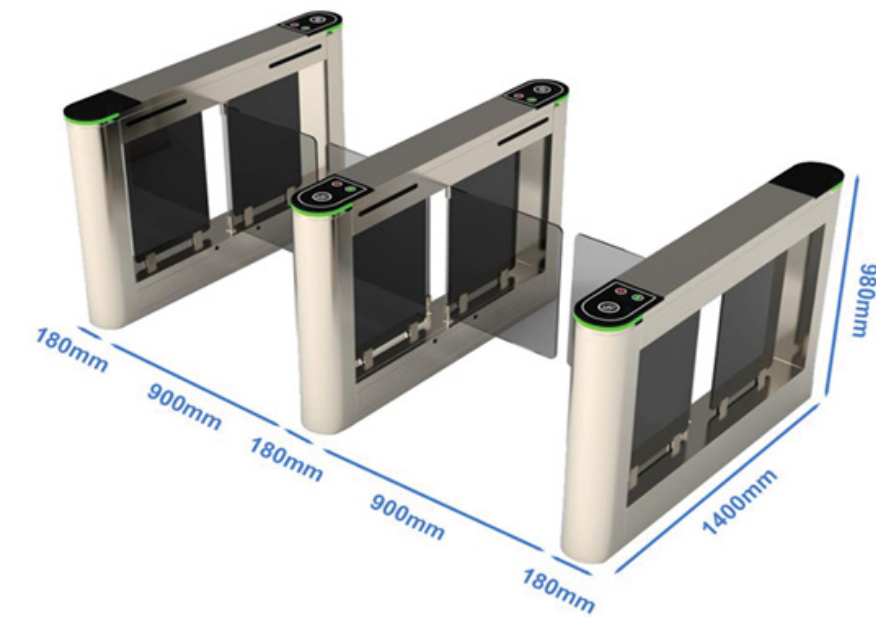

Access control

* RFID reader, Barcode scanner, Facial recognition, Fingerprint reader



Specifications

* Size: 1400x180x980mm	* Material: 1.5/1.2mm 304 SUS
* Pass Width: 600-900mm	* Pass rate: 30-35p/min
* Operating time: 0.2s	* Input: AC100-240V,50/60HZ
* Opening signal: Dry contact	* Working voltage: DC24V
* Drive unit: DC brushless motor	* MCBF: 5 million times

EN16

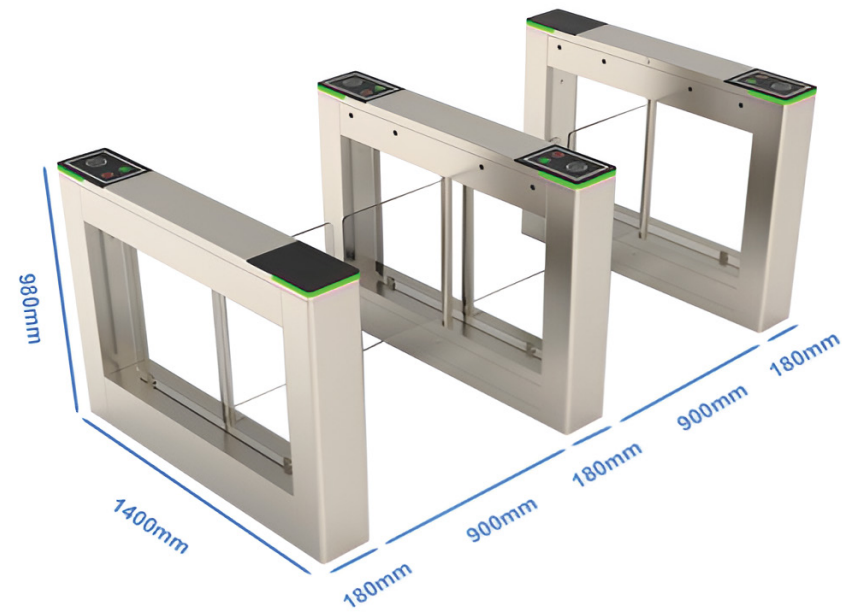

Access control

* RFID reader, Barcode scanner, Facial recognition, Fingerprint reader



Specifications

* Size: 1400x180x980mm	* Material: 1.5/1.2mm 304 SUS
* Pass Width: 600-900mm	* Pass rate: 30-35p/min
* Operating time: 0.2s	* Input: AC100-240V,50/60HZ
* Opening signal: Dry contact	* Working voltage: DC24V
* Drive unit: DC brushless motor	* MCBF: 5 million times

EN17

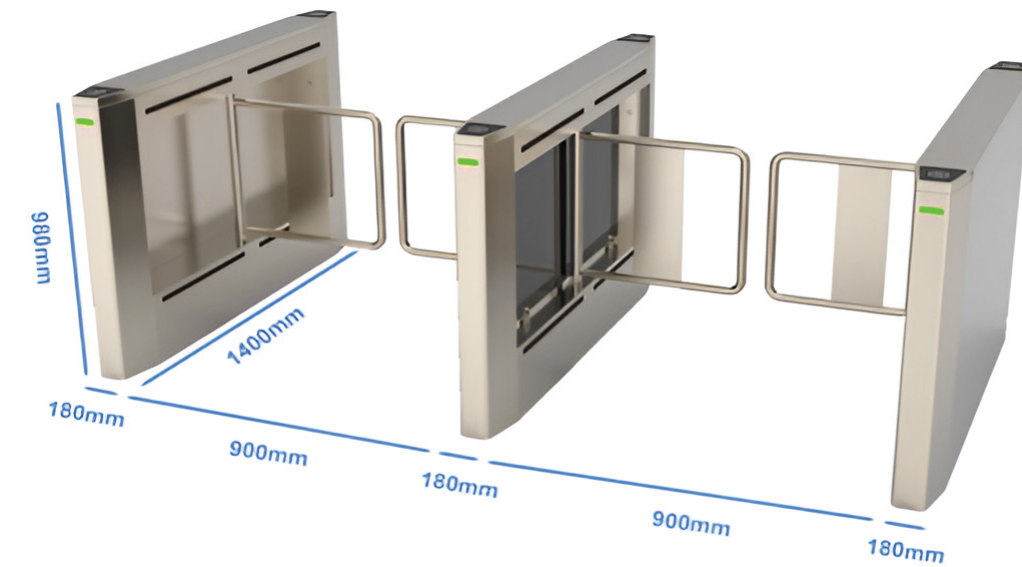

Access control

* RFID reader, Barcode scanner, Facial recognition, Fingerprint reader



Specifications

* Size: 1400x180x980mm	* Material: 1.5/1.2mm 304 SUS
* Pass Width: 600-900mm	* Pass rate: 30-35p/min
* Operating time: 0.2s	* Input: AC100-240V,50/60HZ
* Opening signal: Dry contact	* Working voltage: DC24V
* Drive unit: DC brushless motor	* MCBF: 5 million times

SWING GATE

EN18

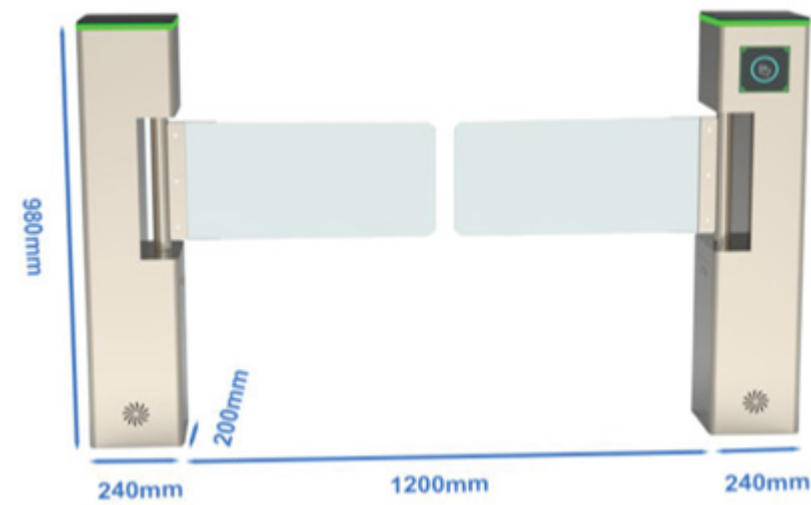

Access control

* RFID reader, Barcode scanner, Facial recognition, Fingerprint reader



Specifications

- | | |
|----------------------------------|-------------------------------|
| * Size: 240x200x980mm | * Material: 1.2/1.0mm 304 SUS |
| * Pass Width: 600-1200mm | * Pass rate: 30-35p/min |
| * Operating time: 0.2s | * Input: AC100-240V,50/60HZ |
| * Opening signal: Dry contact | * Working voltage: DC24V |
| * Drive unit: DC brushless motor | * MCBF: 5 million times |

EN19

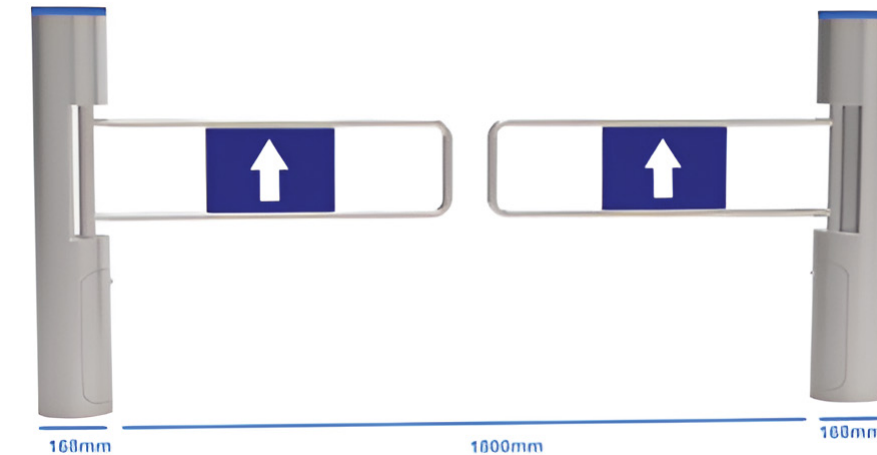

Access control

* RFID reader, Barcode scanner, Facial recognition, Fingerprint reader



Specifications

- | | |
|----------------------------------|-------------------------------|
| * Size: Φ 168x980mm | * Material: 1.2/1.0mm 304 SUS |
| * Pass Width: 600-1800mm | * Pass rate: 30-35p/min |
| * Operating time: 0.2s | * Input: AC100-240V,50/60HZ |
| * Opening signal: Dry contact | * Working voltage: DC24V |
| * Drive unit: DC brushless motor | * MCBF: 5 million times |

SWING GATE

EN20

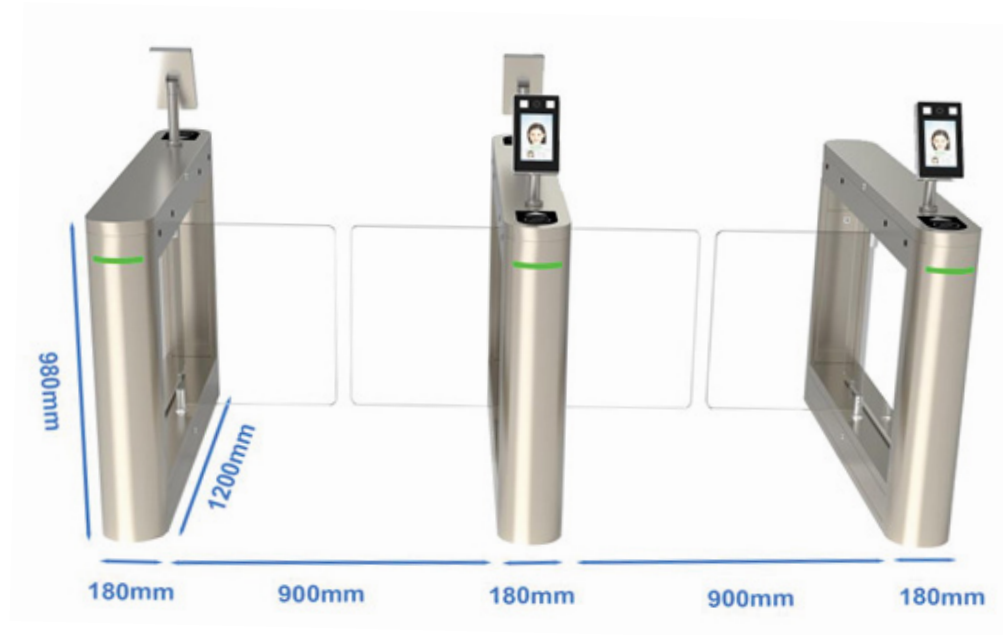

Access control

* RFID reader, Barcode scanner, Facial recognition, Fingerprint reader



Specifications

- | | |
|----------------------------------|-------------------------------|
| * Size: 1200x180x980mm | * Material: 1.2/1.0mm 304 SUS |
| * Pass Width: 600-900mm | * Pass rate: 30-35p/min |
| * Operating time: 0.2s | * Input: AC100-240V,50/60HZ |
| * Opening signal: Dry contact | * Working voltage: DC24V |
| * Drive unit: DC brushless motor | * MCBF: 5 million times |

EN26

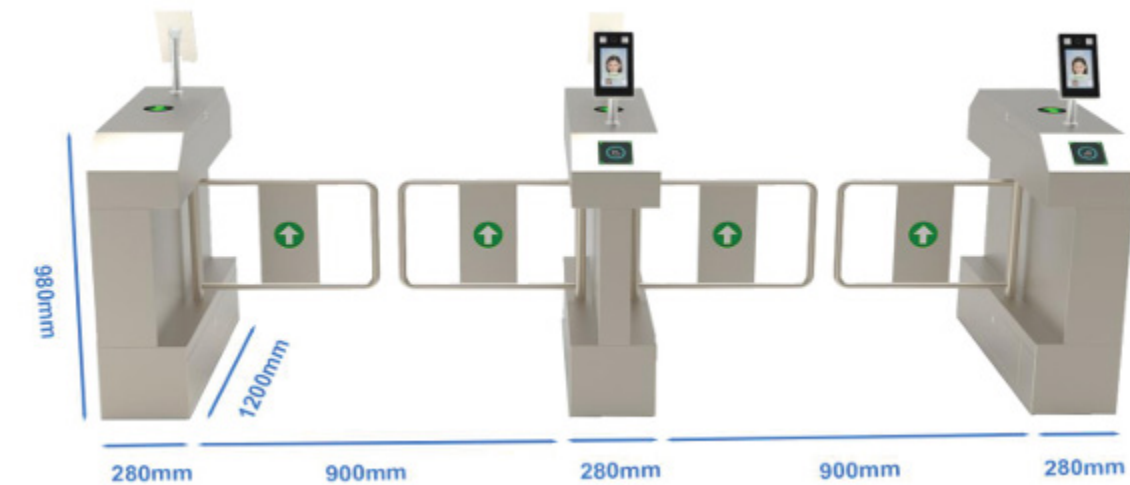

Access control

* RFID reader, Barcode scanner, Facial recognition, Fingerprint reader



Specifications

- | | |
|----------------------------------|-------------------------------|
| * Size: 1200x180x980mm | * Material: 1.2/1.0mm 304 SUS |
| * Pass Width: 600-900mm | * Pass rate: 30-35p/min |
| * Operating time: 0.2s | * Input: AC100-240V,50/60HZ |
| * Opening signal: Dry contact | * Working voltage: DC24V |
| * Drive unit: DC brushless motor | * MCBF: 5 million times |

SWING GATE

EN27

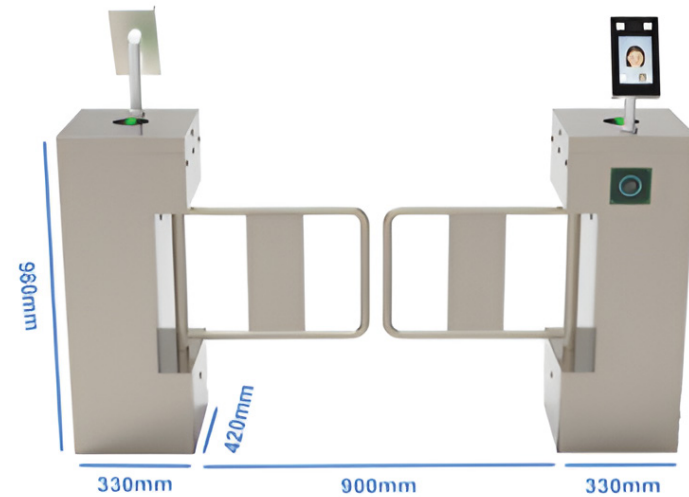

Access control

* RFID reader, Barcode scanner, Facial recognition, Fingerprint reader



Specifications

- | | |
|----------------------------------|-------------------------------|
| * Size: 1200x180x980mm | * Material: 1.2/1.0mm 304 SUS |
| * Pass Width: 600-900mm | * Pass rate: 30-35p/min |
| * Operating time: 0.2s | * Input: AC100-240V,50/60HZ |
| * Opening signal: Dry contact | * Working voltage: DC24V |
| * Drive unit: DC brushless motor | * MCBF: 5 million times |

EN28

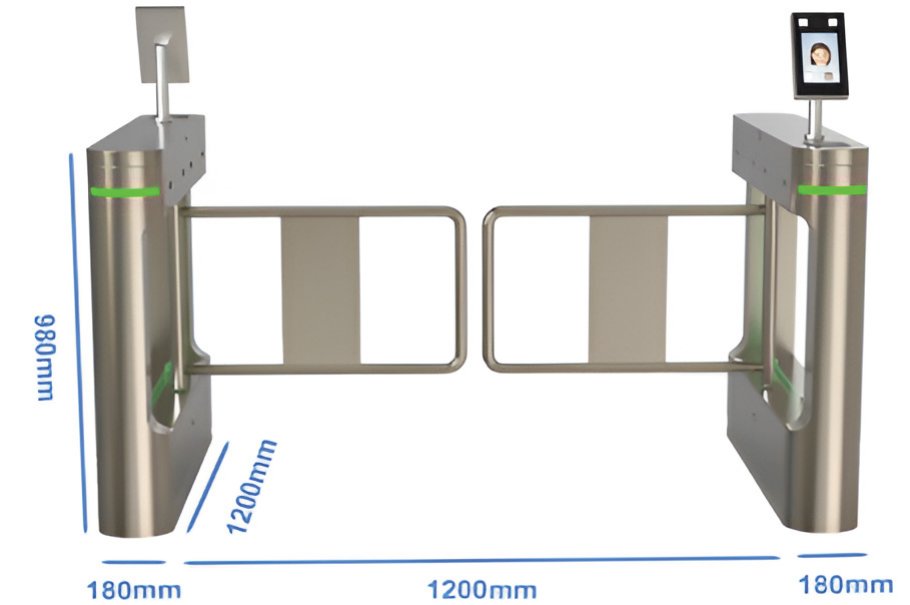

Access control

* RFID reader, Barcode scanner, Facial recognition, Fingerprint reader



Specifications

- | | |
|----------------------------------|-------------------------------|
| * Size: 1200x180x980mm | * Material: 1.2/1.0mm 304 SUS |
| * Pass Width: 600-900mm | * Pass rate: 30-35p/min |
| * Operating time: 0.2s | * Input: AC100-240V,50/60HZ |
| * Opening signal: Dry contact | * Working voltage: DC24V |
| * Drive unit: DC brushless motor | * MCBF: 5 million times |

SPEED GATE

Introduction

- Structure: The entire turnstile is made of 304 stainless steel sheet metal, rust proof, sturdy and durable.
- Drive motor: DC24V brushless servo motor
- Dimensions: length 1500 x width 120 x height 980 (mm) / customized size
- Pass width: 600-900 (mm)
- Pass direction: one-directional or bidirectional
- Working environment: indoor and outdoor (preferably with a canopy)

Basic functions

- Automatic reset function
- Ultra high brightness traffic indication function
- Multiple pass mode functions
- Traffic request memory function
- Power off and open automatically function
- Anti collision function
- Anti tailgating function
- Anti pinch function: Infrared/mechanical
- Multiple control functions
- External buttons, remote controls, barcode scanners, IC or ID reader
- Gate opening and closing speed adjustable
- Remote control function: The gate can be remotely controlled by connecting to an RS485 card or TCP to RS485 via a computer
- Automatic locking function: If the card swipe fails to pass within the specified time, the gate will be locked again to cancel the passage, with a time of 1-60 seconds

Extend functions

- Traffic limit function
- Counting function: add a counter to count the number of entering & exiting
- Anti reverse passage function
- Illegal intrusion alarm

The color of cabinet is optional.

Application scenarios

- Offices: commercial buildings, government agencies, etc.
- Science and education: universities, research institutes, libraries, etc.
- Commercial service: supermarkets, shopping malls, hotels, clubs, banks, etc.
- Leisure & entertainment venues: parks, scenic spots, amusement parks, etc.
- Transportation: bus stations, train stations, subway stations, airports, etc.

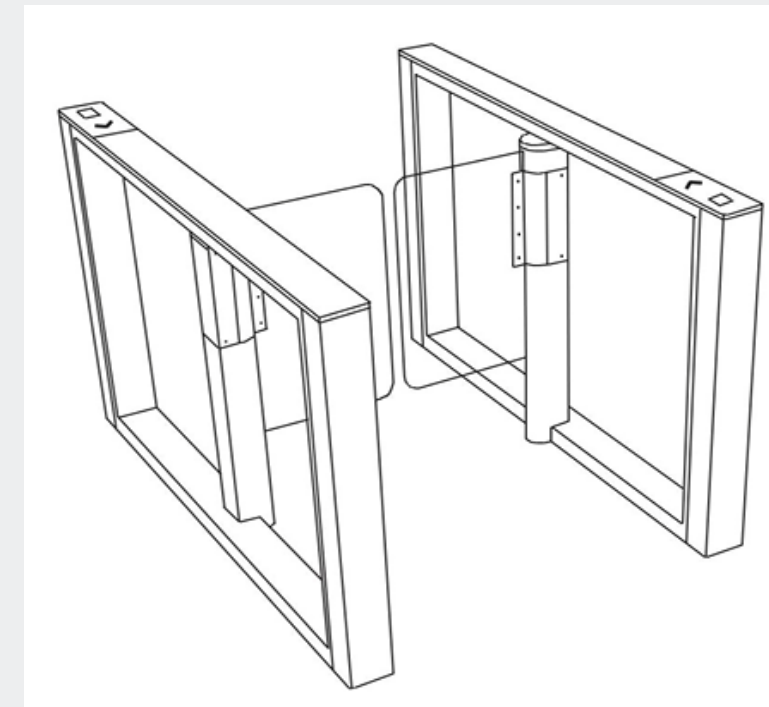

SPEED GATE

EN301

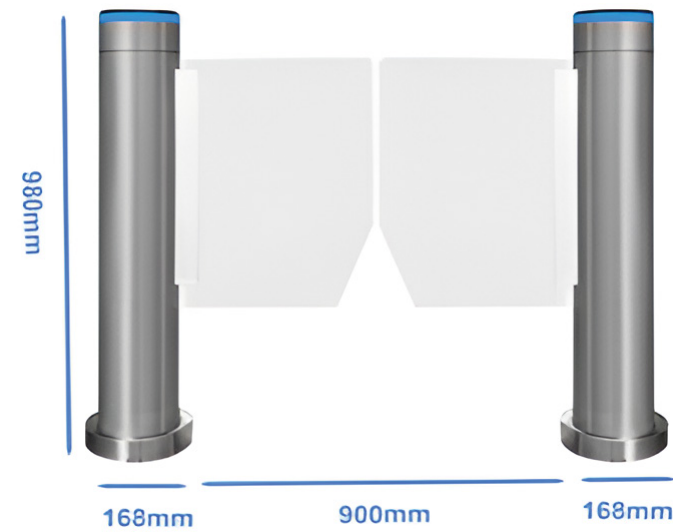

Access control

* RFID reader, Barcode scanner, Facial recognition, Fingerprint reader

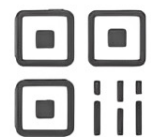

Specifications

- | | |
|----------------------------------|-------------------------------|
| * Size: Φ 168x980mm | * Material: 1.5/1.2mm 304 SUS |
| * Pass Width: 600-900mm | * Pass rate: 30-35p/min |
| * Operating time: 0.2s | * Input: AC100-240V,50/60HZ |
| * Opening signal: Dry contact | * Working voltage: DC24V |
| * Drive unit: DC brushless motor | * MCBF: 5 million times |

EN330

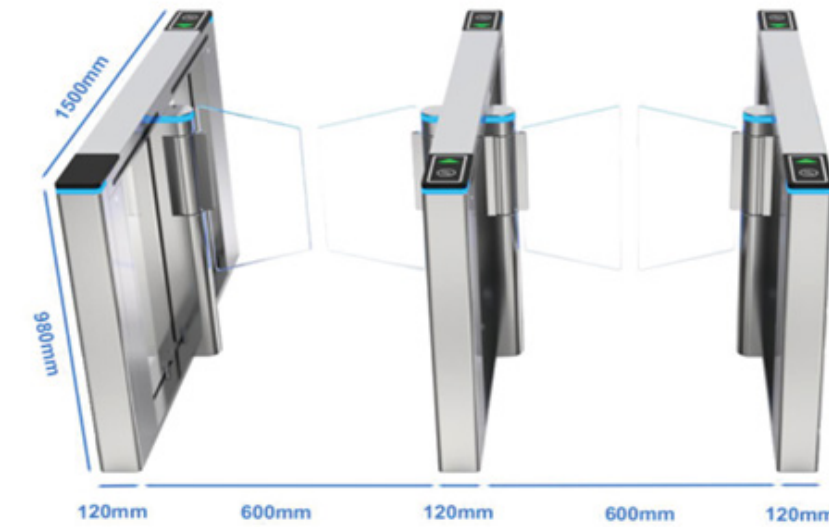

Access control

* RFID reader, Barcode scanner, Facial recognition, Fingerprint reader



Specifications

- | | |
|----------------------------------|-------------------------------|
| * Size: 1500x120x980mm | * Material: 1.5/1.2mm 304 SUS |
| * Pass Width: 600-900mm | * Pass rate: 30-35p/min |
| * Operating time: 0.2s | * Input: AC100-240V,50/60HZ |
| * Opening signal: Dry contact | * Working voltage: DC24V |
| * Drive unit: DC brushless motor | * MCBF: 5 million times |

SPEED GATE

EN340

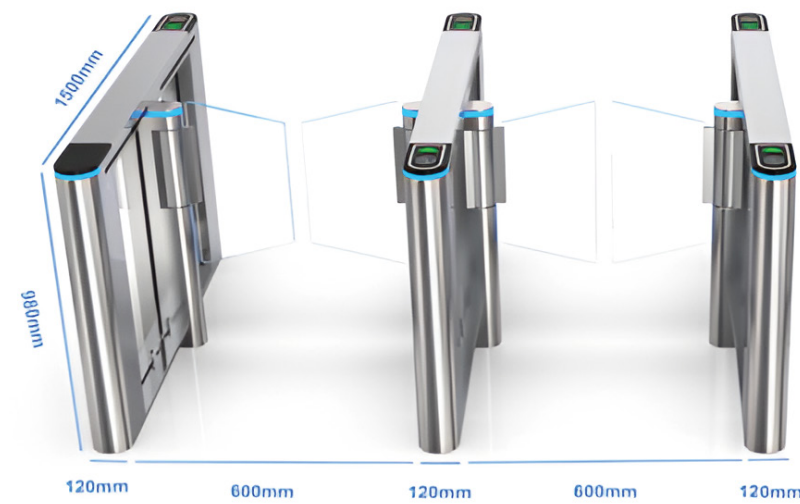

Access control

* RFID reader, Barcode scanner, Facial recognition, Fingerprint reader



Specifications

- | | |
|----------------------------------|-------------------------------|
| * Size: 1500x120x980mm | * Material: 1.5/1.2mm 304 SUS |
| * Pass Width: 600-900mm | * Pass rate: 30-35p/min |
| * Operating time: 0.2s | * Input: AC100-240V,50/60HZ |
| * Opening signal: Dry contact | * Working voltage: DC24V |
| * Drive unit: DC brushless motor | * MCBF: 5 million times |

EN370

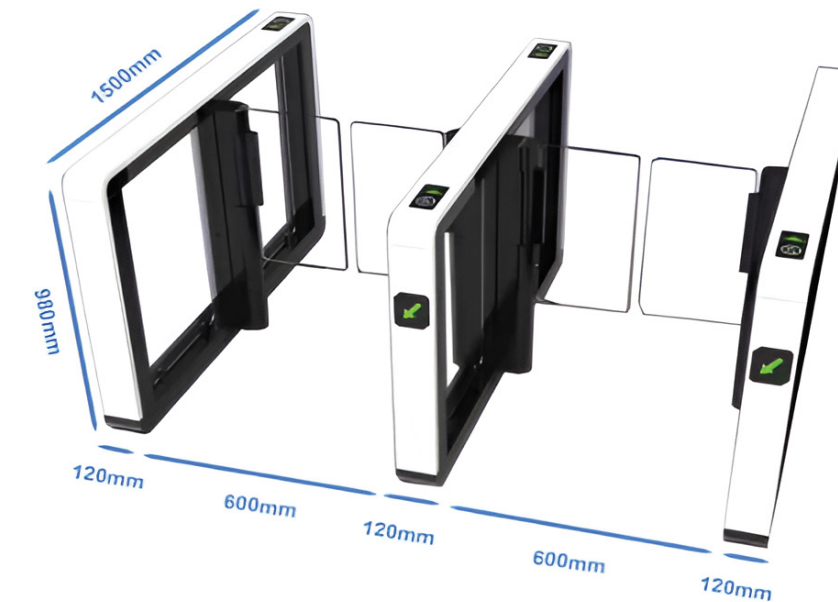

Access control

* RFID reader, Barcode scanner, Facial recognition, Fingerprint reader



Specifications

- | | |
|----------------------------------|-------------------------------|
| * Size: 1500x120x980mm | * Material: 1.5/1.2mm 304 SUS |
| * Pass Width: 600-900mm | * Pass rate: 30-35p/min |
| * Operating time: 0.2s | * Input: AC100-240V,50/60HZ |
| * Opening signal: Dry contact | * Working voltage: DC24V |
| * Drive unit: DC brushless motor | * MCBF: 5 million times |

SPEED GATE

EN380

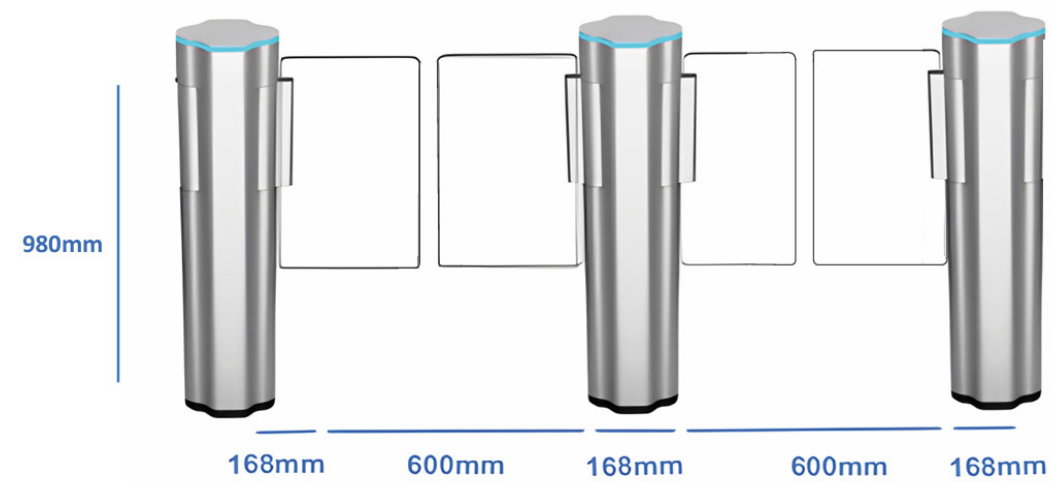

Access control

* RFID reader, Barcode scanner, Facial recognition, Fingerprint reader



Specifications

* Size: Φ 168x980mm	* Material: 1.5mm aluminum alloy
* Pass Width: 600-900mm	* Pass rate: 30-35p/min
* Operating time: 0.2s	* Input: AC100-240V,50/60HZ
* Opening signal: Dry contact	* Working voltage: DC24V
* Drive unit: DC brushless motor	* MCBF: 5 million times

EN390

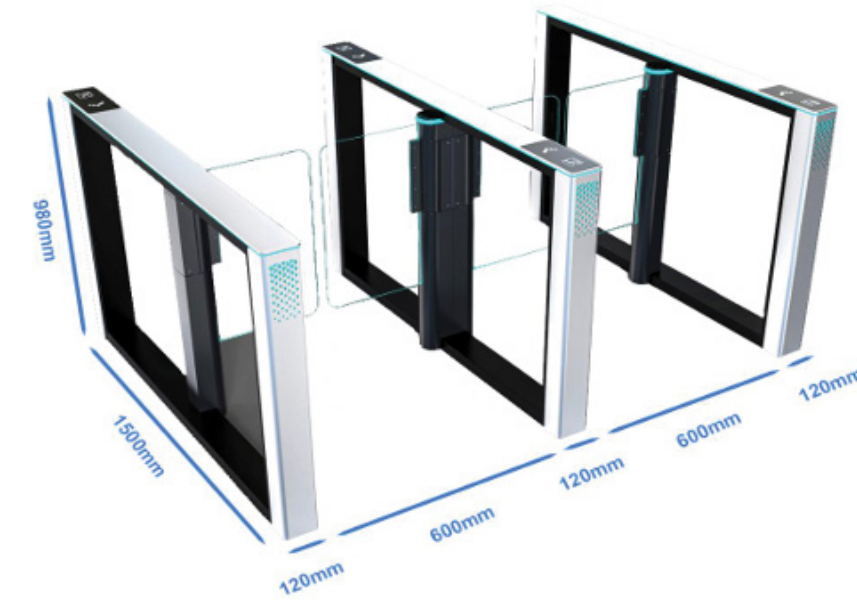

Access control

* RFID reader, Barcode scanner, Facial recognition, Fingerprint reader



Specifications

* Size: 1500x120x980mm	* Material: 1.5mm aluminum alloy
* Pass Width: 600-900mm	* Pass rate: 30-35p/min
* Operating time: 0.2s	* Input: AC100-240V,50/60HZ
* Opening signal: Dry contact	* Working voltage: DC24V
* Drive unit: DC brushless motor	* MCBF: 5 million times

SPEED GATE

EN510

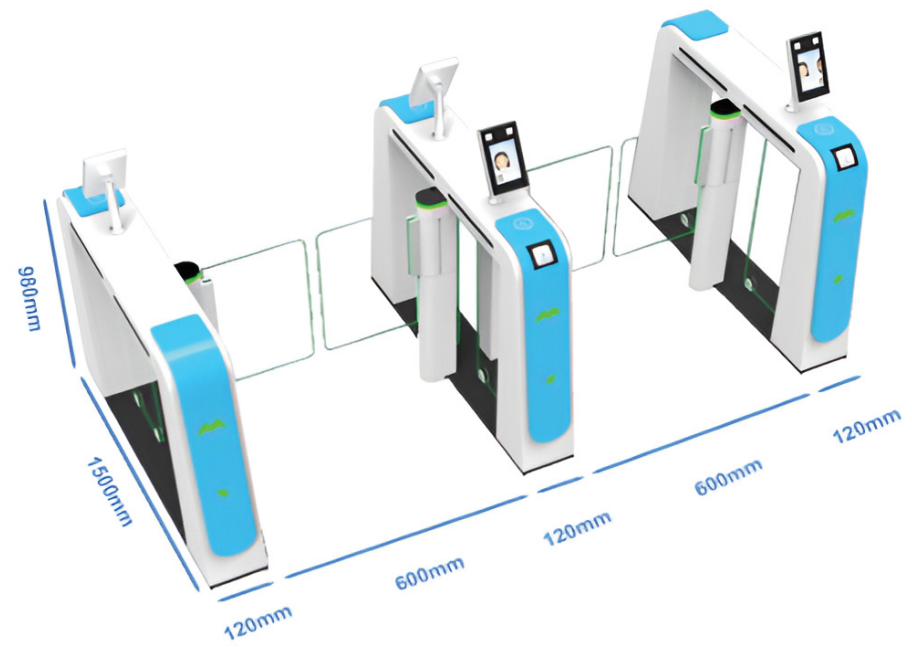

EN530



Access control

* RFID reader, Barcode scanner, Facial recognition, Fingerprint reader



Access control

* RFID reader, Barcode scanner, Facial recognition, Fingerprint reader



Specifications

* Size: 1500x120x980mm	* Material: 1.5/1.2mm 304 SUS
* Pass Width: 600-900mm	* Pass rate: 30-35p/min
* Operating time: 0.2s	* Input: AC100-240V,50/60HZ
* Opening signal: Dry contact	* Working voltage: DC24V
* Drive unit: DC brushless motor	* MCBF: 5 million times

Specifications

* Size: 1500x120x980mm	* Material: 1.5/1.2mm 304 SUS
* Pass Width: 600-900mm	* Pass rate: 30-35p/min
* Operating time: 0.2s	* Input: AC100-240V,50/60HZ
* Opening signal: Dry contact	* Working voltage: DC24V
* Drive unit: DC brushless motor	* MCBF: 5 million times

FLAP BARRIER

Introduction

- Structure: The entire turnstile is made of 304 stainless steel sheet metal, rust proof, sturdy and durable.
- Drive motor: DC24V brushless motor
- Dimensions: length 1200 x width 300 x height 980 (mm) / customized size
- Pass width: 550 or 900 (mm)
- Pass direction: one-directional or bidirectional
- Working environment: indoor and outdoor (preferably with a canopy)

Basic functions

- Automatic reset function
- Ultra high brightness traffic indication function
- Multiple pass mode functions
- Traffic request memory function
- Power off and open automatically function
- Anti collision function
- Anti tailgating function
- Anti pinch function: Infrared/mechanical
- Multiple control functions
- External buttons, remote controls, barcode scanners, IC or ID reader
- Gate opening and closing speed adjustable
- Remote control function: The gate can be remotely controlled by connecting to an RS485 card or TCP to RS485 via a computer
- Automatic locking function: If the card swipe fails to pass within the specified time, the gate will be locked again to cancel the passage, with a time of 1-60 seconds

Extend functions

- Traffic limit function
- Counting function: add a counter to count the number of entering & exiting
- Anti reverse passage function
- Illegal intrusion alarm

The color of cabinet is optional.

Application scenarios

- Offices: commercial buildings, government agencies, etc.
- Science and education: universities, research institutes, libraries, etc.
- Commercial service: supermarkets, shopping malls, hotels, clubs, banks, etc.
- Leisure & entertainment venues: parks, scenic spots, amusement parks, etc.
- Transportation: bus stations, train stations, subway stations, airports, etc.

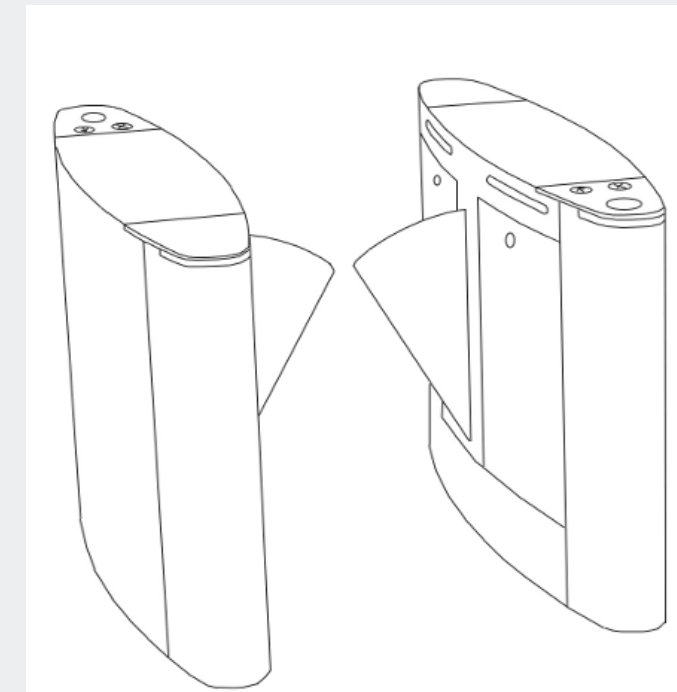

FLAP BARRIER

EN01



Access control

* RFID reader, Barcode scanner, Facial recognition, Fingerprint reader



Specifications

* Size: 1200x300x980mm	* Material: 1.2/1.0mm 304 SUS
* Pass Width: 550mm	* Pass rate: 30-35p/min
* Operating time: 0.2s	* Input: AC100-240V,50/60HZ
* Opening signal: Dry contact	* Working voltage: DC24V
* Drive unit: DC brushless motor	* MCBF: 5 million times

EN03

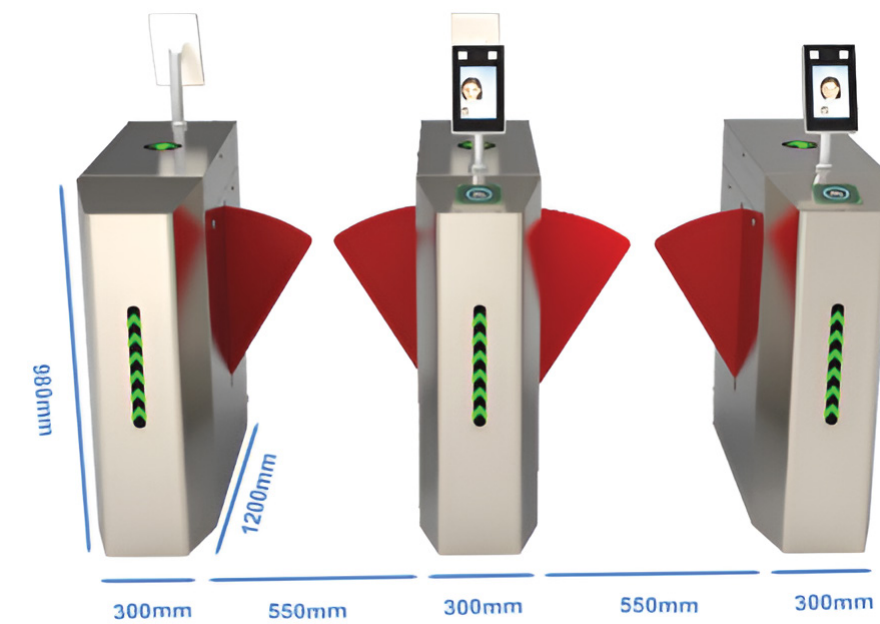

Access control

* RFID reader, Barcode scanner, Facial recognition, Fingerprint reader



Specifications

* Size: 1200x300x980mm	* Material: 1.2/1.0mm 304 SUS
* Pass Width: 550mm	* Pass rate: 30-35p/min
* Operating time: 0.2s	* Input: AC100-240V,50/60HZ
* Opening signal: Dry contact	* Working voltage: DC24V
* Drive unit: DC brushless motor	* MCBF: 5 million times

FLAP BARRIER

EN04

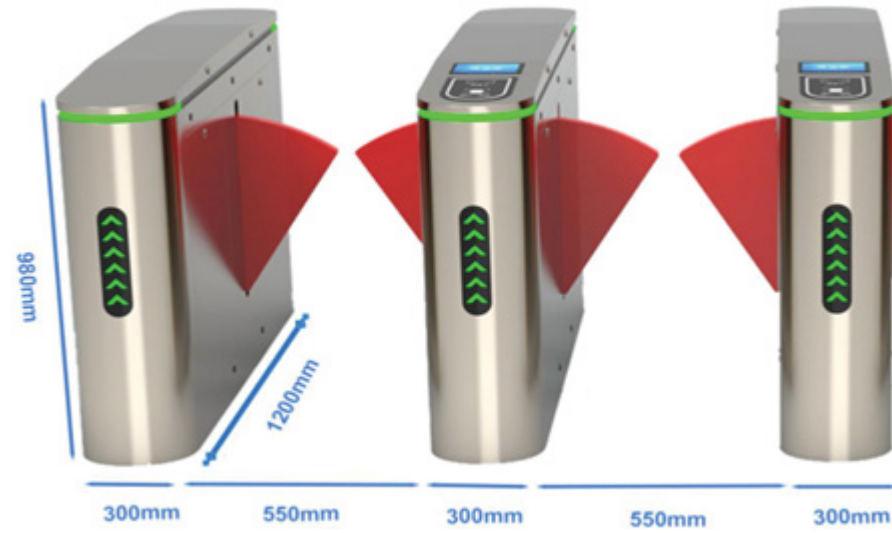

Access control

* RFID reader, Barcode scanner, Facial recognition, Fingerprint reader



Specifications

- | | |
|----------------------------------|-------------------------------|
| * Size: 1200x300x980mm | * Material: 1.2/1.0mm 304 SUS |
| * Pass Width: 550mm | * Pass rate: 30-35p/min |
| * Operating time: 0.2s | * Input: AC100-240V,50/60HZ |
| * Opening signal: Dry contact | * Working voltage: DC24V |
| * Drive unit: DC brushless motor | * MCBF: 5 million times |

EN07

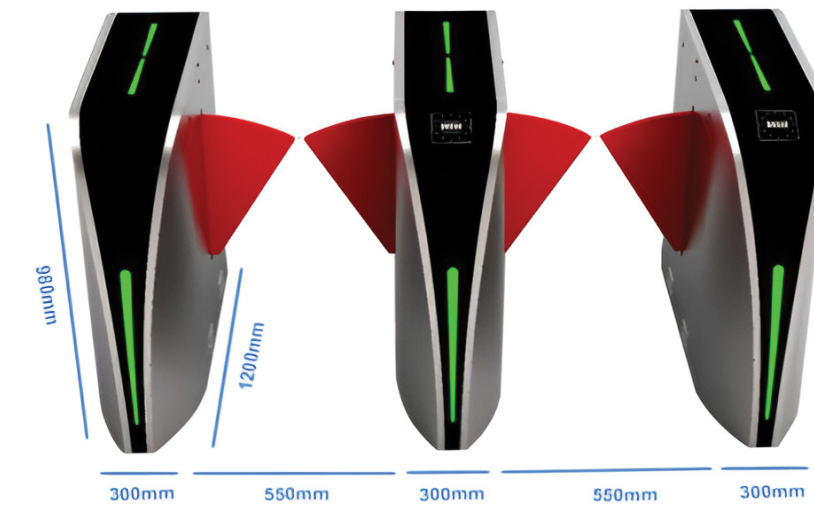

Access control

* RFID reader, Barcode scanner, Facial recognition, Fingerprint reader

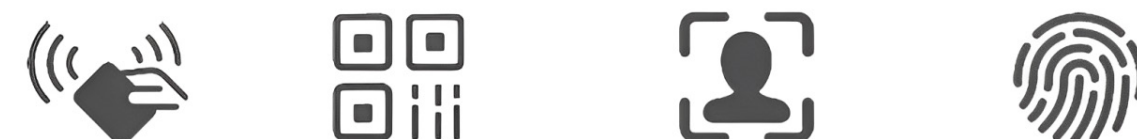

Specifications

- | | |
|----------------------------------|-------------------------------|
| * Size: 1200x300x980mm | * Material: 1.5/1.2mm 304 SUS |
| * Pass Width: 550mm | * Pass rate: 30-35p/min |
| * Operating time: 0.2s | * Input: AC100-240V,50/60HZ |
| * Opening signal: Dry contact | * Working voltage: DC24V |
| * Drive unit: DC brushless motor | * MCBF: 5 million times |

FLAP BARRIER

EN08

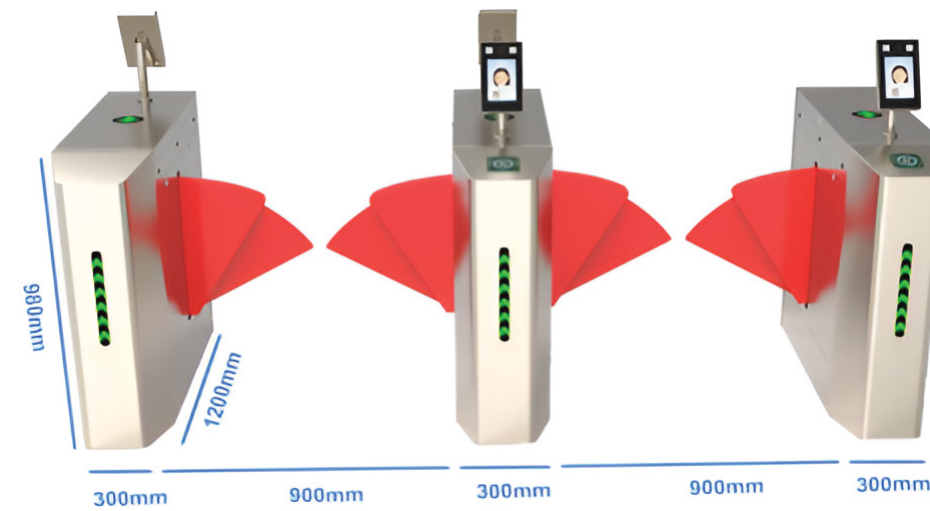

Access control

* RFID reader, Barcode scanner, Facial recognition, Fingerprint reader



Specifications

* Size: 1200x300x980mm	* Material: 1.2/1.0mm 304 SUS
* Pass Width: 550mm	* Pass rate: 30-35p/min
* Operating time: 0.2s	* Input: AC100-240V,50/60HZ
* Opening signal: Dry contact	* Working voltage: DC24V
* Drive unit: DC brushless motor	* MCBF: 5 million times

EN10

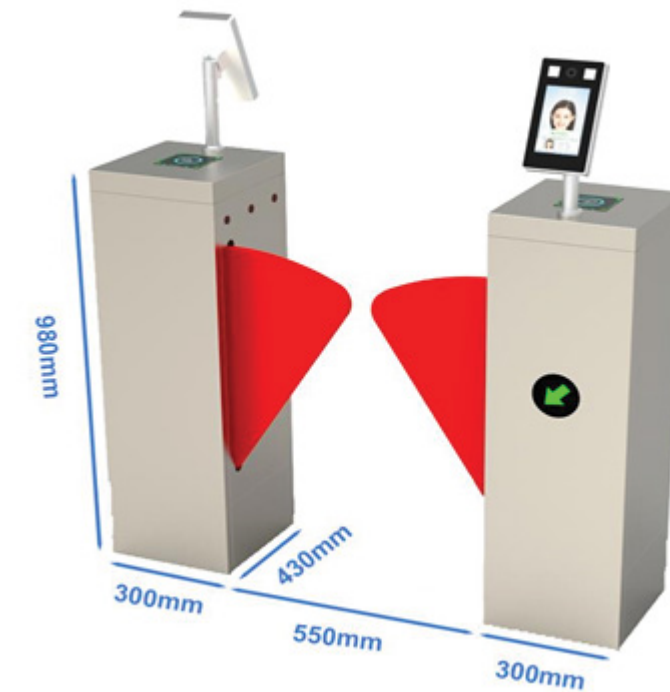

Access control

* RFID reader, Barcode scanner, Facial recognition, Fingerprint reader



Specifications

* Size: 430x300x980mm	* Material: 1.2/1.0mm 304 SUS
* Pass Width: 550mm	* Pass rate: 30-35p/min
* Operating time: 0.2s	* Input: AC100-240V,50/60HZ
* Opening signal: Dry contact	* Working voltage: DC24V
* Drive unit: DC brushless motor	* MCBF: 5 million times

FLAP BARRIER

EN11

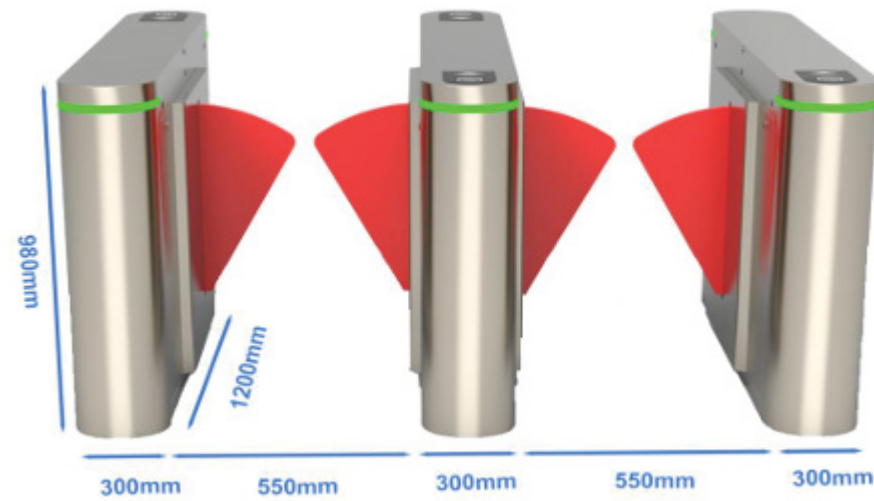

Access control

* RFID reader, Barcode scanner, Facial recognition, Fingerprint reader



Specifications

- | | |
|----------------------------------|-------------------------------|
| * Size: 1200x300x980mm | * Material: 1.2/1.0mm 304 SUS |
| * Pass Width: 550mm | * Pass rate: 30-35p/min |
| * Operating time: 0.2s | * Input: AC100-240V,50/60HZ |
| * Opening signal: Dry contact | * Working voltage: DC24V |
| * Drive unit: DC brushless motor | * MCBF: 5 million times |

EN12

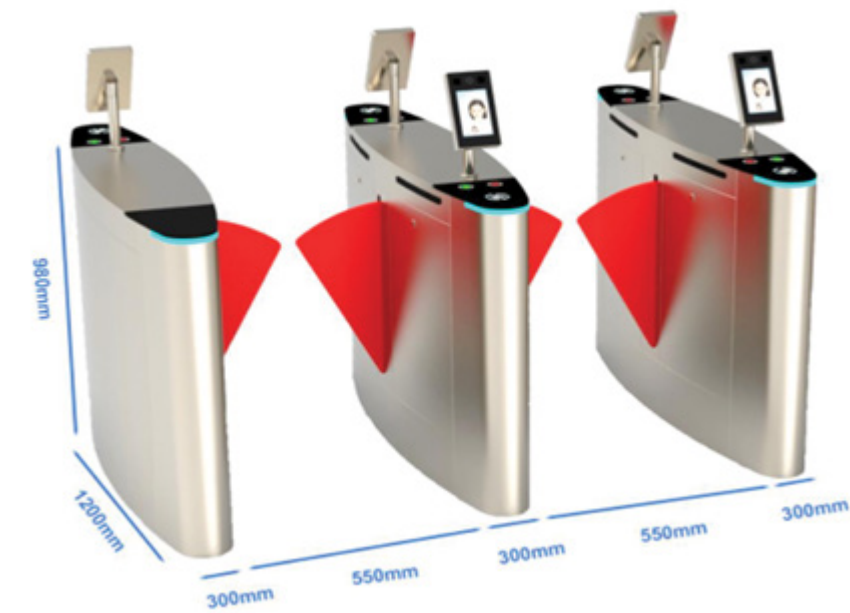

Access control

* RFID reader, Barcode scanner, Facial recognition, Fingerprint reader



Specifications

- | | |
|----------------------------------|-------------------------------|
| * Size: 1200x300x980mm | * Material: 1.2/1.0mm 304 SUS |
| * Pass Width: 550mm | * Pass rate: 30-35p/min |
| * Operating time: 0.2s | * Input: AC100-240V,50/60HZ |
| * Opening signal: Dry contact | * Working voltage: DC24V |
| * Drive unit: DC brushless motor | * MCBF: 5 million times |

SLIDING GATE

Introduction

- Structure: The entire turnstile is made of 304 stainless steel sheet metal, rust proof, sturdy and durable.
- Drive motor: DC24V brushless motor
- Dimensions: length 1400 x width 330 x height 980 (mm) / customized size
- Pass width: 600 or 900 (mm)
- Pass direction: one-directional or bidirectional
- Working environment: indoor and outdoor (preferably with a canopy)

Basic functions

- Automatic reset function
- Ultra high brightness traffic indication function
- Multiple pass mode functions
- Traffic request memory function
- Power off and open automatically function
- Anti collision function
- Anti tailgating function
- Anti pinch function: Infrared/mechanical
- Multiple control functions
- External buttons, remote controls, barcode scanners, IC or ID reader
- Gate opening and closing speed adjustable
- Remote control function: The gate can be remotely controlled by connecting to an RS485 card or TCP to RS485 via a computer
- Automatic locking function: If the card swipe fails to pass within the specified time, the gate will be locked again to cancel the passage, with a time of 1-60 seconds

Extend functions

- Traffic limit function
- Counting function: add a counter to count the number of entering & exiting
- Anti reverse passage function
- Illegal intrusion alarm

The color of cabinet is optional.

Application scenarios

- Offices: commercial buildings, government agencies, etc.
- Science and education: universities, research institutes, libraries, etc.
- Commercial service: supermarkets, shopping malls, hotels, clubs, banks, etc.
- Leisure & entertainment venues: parks, scenic spots, amusement parks, etc.
- Transportation: bus stations, train stations, subway stations, airports, etc.

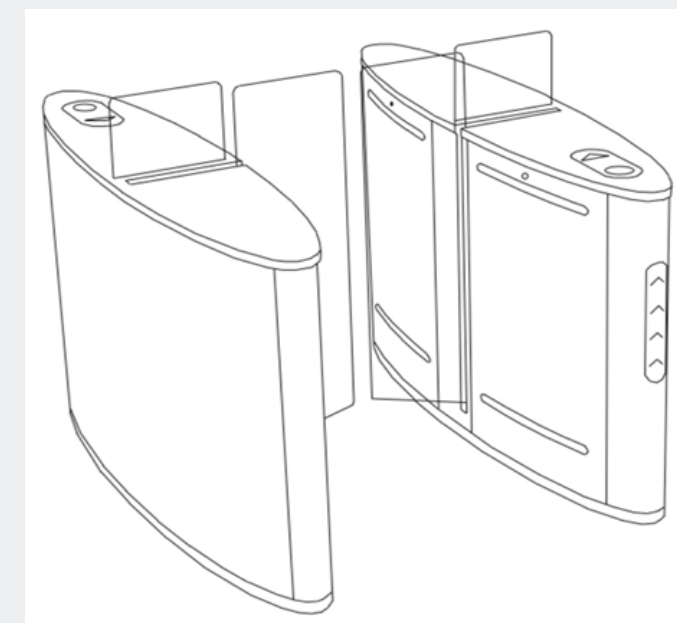

SLIDING GATE

EN300



Access control

* RFID reader, Barcode scanner, Facial recognition, Fingerprint reader



Specifications

- | | |
|----------------------------------|-------------------------------|
| * Size: 1400x330x980mm | * Material: 1.5/1.2mm 304 SUS |
| * Pass Width: 600mm | * Pass rate: 30-35p/min |
| * Operating time: 0.2s | * Input: AC100-240V,50/60HZ |
| * Opening signal: Dry contact | * Working voltage: DC24V |
| * Drive unit: DC brushless motor | * MCBF: 5 million times |

EN350



Access control

* RFID reader, Barcode scanner, Facial recognition, Fingerprint reader



Specifications

- | | |
|----------------------------------|-------------------------------|
| * Size: 1400x330x980mm | * Material: 1.5/1.2mm 304 SUS |
| * Pass Width: 600mm | * Pass rate: 30-35p/min |
| * Operating time: 0.2s | * Input: AC100-240V,50/60HZ |
| * Opening signal: Dry contact | * Working voltage: DC24V |
| * Drive unit: DC brushless motor | * MCBF: 5 million times |

SLIDING GATE

EN390

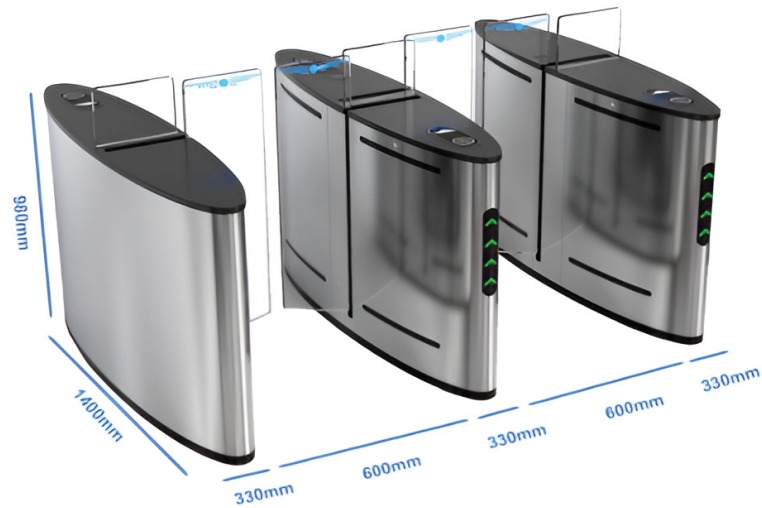

Access control

* RFID reader, Barcode scanner, Facial recognition, Fingerprint reader



Specifications

* Size: 1400x330x980mm	* Material: 1.5/1.2mm 304 SUS
* Pass Width: 600mm	* Pass rate: 30-35p/min
* Operating time: 0.2s	* Input: AC100-240V,50/60HZ
* Opening signal: Dry contact	* Working voltage: DC24V
* Drive unit: DC brushless motor	* MCBF: 5 million times

EN500

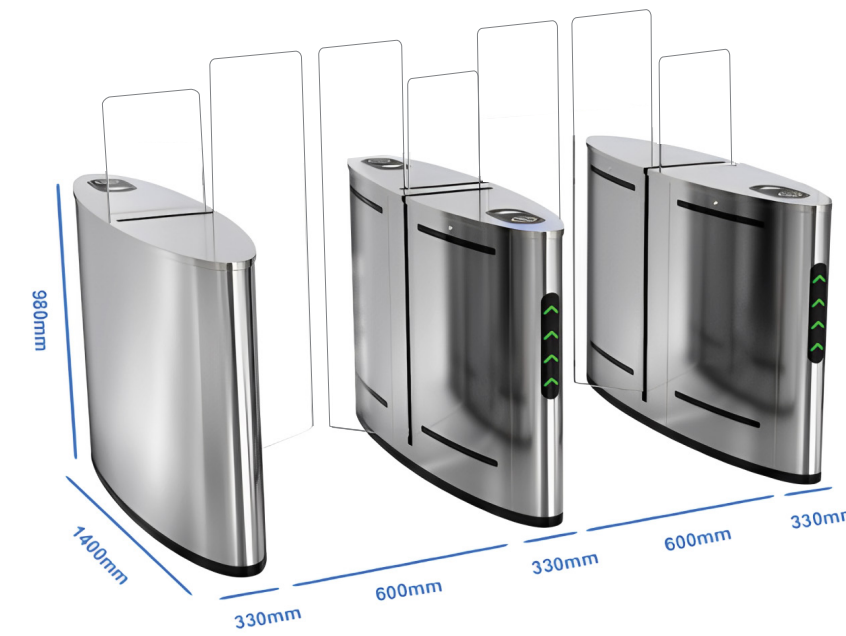

Access control

* RFID reader, Barcode scanner, Facial recognition, Fingerprint reader



Specifications

* Size: 1400x330x980mm	* Material: 1.5/1.2mm 304 SUS
* Pass Width: 600mm	* Pass rate: 30-35p/min
* Operating time: 0.2s	* Input: AC100-240V,50/60HZ
* Opening signal: Dry contact	* Working voltage: DC24V
* Drive unit: DC brushless motor	* MCBF: 5 million times

FULL HEIGHT TURNSTILE

Introduction

- Structure: The entire turnstile is made of 304 stainless steel sheet metal, rust proof, sturdy and durable.
- Drive motor: solenoid semi-automatic or servo motor automatic
- Dimensions: length 1450 x width 1450 x height 2200 (mm) / customized size
- Pass width: 600 (mm)
- Pass direction: one-directional or bidirectional
- Working environment: indoor and outdoor (preferably with a canopy)

Basic functions

- Automatic reset function
- Ultra high brightness traffic indication function
- Multiple travel mode functions
- Traffic request memory function
- Power off and automatically unlock or stay lock, use a key to unlock.
- Anti collision function
- Multiple control functions
- External buttons, remote controls, barcode scanners, IC or ID reader
- Anti tailgating function
- Remote control function: The gate can be remotely controlled by connecting to an RS485 card or TCP to RS485 via a computer
- Automatic locking function: If the card swipe fails to pass within the specified time, the gate will be locked again to cancel the passage, with a time of 1-60 seconds.

Extend functions

- Traffic limit function
 - Counting function: add a counter to count the number of entering & exiting
 - Anti reverse passage function
 - Illegal intrusion alarm
- The color of cabinet is optional*

Application scenarios

- Offices: commercial buildings, government agencies, etc.
- Science and education: universities, research institutes, libraries, etc.
- Commercial service: supermarkets, shopping malls, hotels, clubs, banks, etc.
- Leisure & entertainment venues: parks, scenic spots, amusement parks, etc.
- Transportation: bus stations, train stations, subway stations, airports, etc.

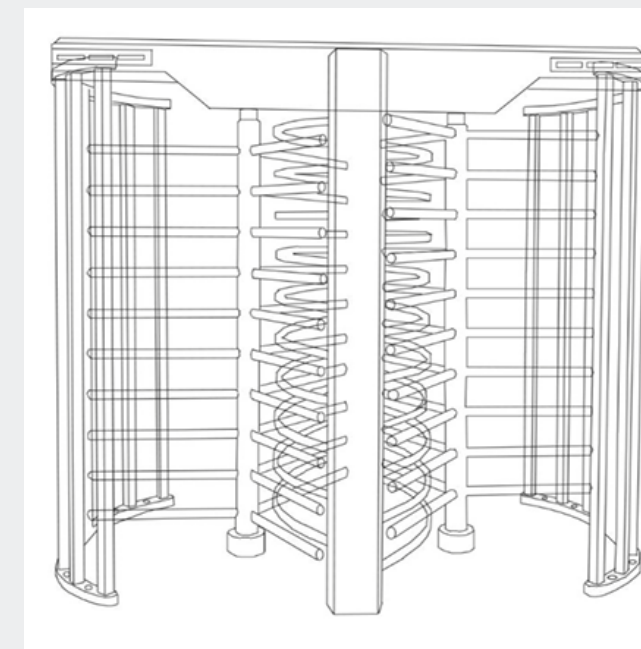

FULL HEIGHT TURNSTILE

EN01

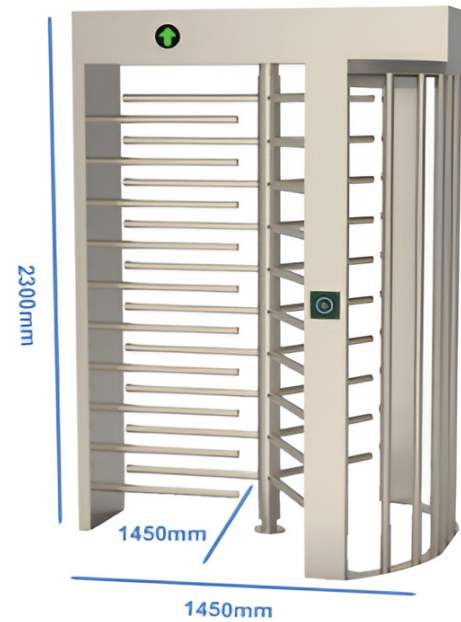

Access control

* RFID reader, Barcode scanner, Facial recognition, Fingerprint reader

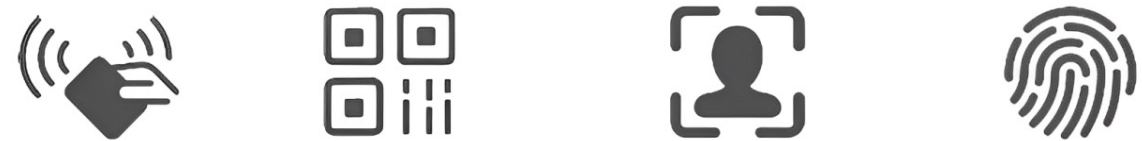

Specifications

* Size: 1450x1450x2300mm	* Material: 1.2/1.0mm 304 SUS
* Pass Width: 600mm	* Pass rate: 20-25p/min
* Operating time: 0.2s	* Input: AC100-240V,50/60HZ
* Opening signal: Dry contact	* Working voltage: DC24V
* Mechanism: Pro solenoid lock	* MCBF: 5 million times

EN02

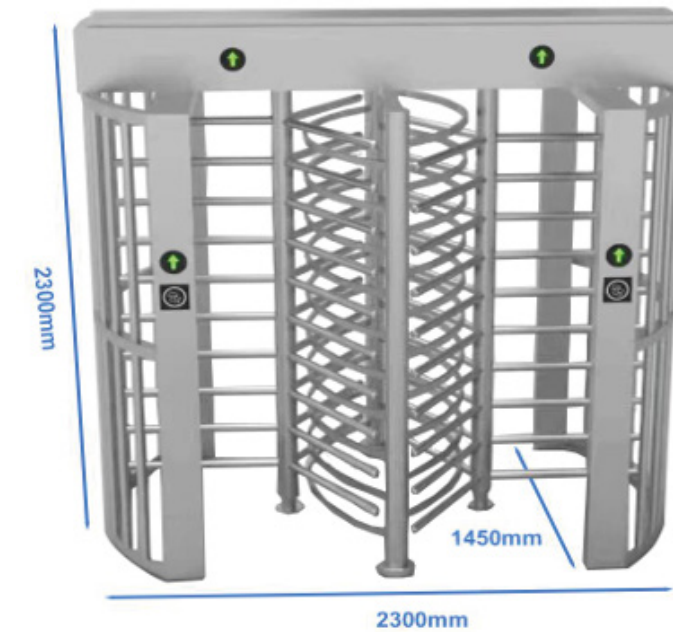

Access control

* RFID reader, Barcode scanner, Facial recognition, Fingerprint reader



Specifications

* Size: 1450x1450x2300mm	* Material: 1.2/1.0mm 304 SUS
* Pass Width: 600mm	* Pass rate: 20-25p/min
* Operating time: 0.2s	* Input: AC100-240V,50/60HZ
* Opening signal: Dry contact	* Working voltage: DC24V
* Mechanism: Pro solenoid lock	* MCBF: 5 million times

FULL HEIGHT TURNSTILE

EN04

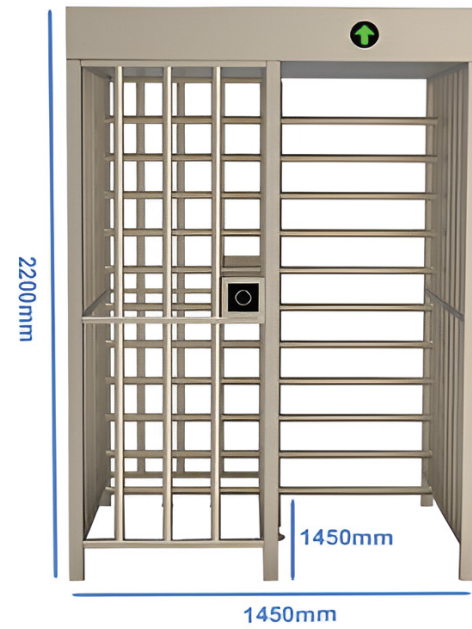

Access control

* RFID reader, Barcode scanner, Facial recognition, Fingerprint reader



Specifications

* Size: 1450x1450x2200mm	* Material: 1.2/1.0mm 304 SUS
* Pass Width: 550mm	* Pass rate: 30-35p/min
* Operating time: 0.2s	* Input: AC100-240V,50/60HZ
* Opening signal: Dry contact	* Working voltage: DC24V
* Mechanism: Pro solenoid lock	* MCBF: 5 million times

EN05

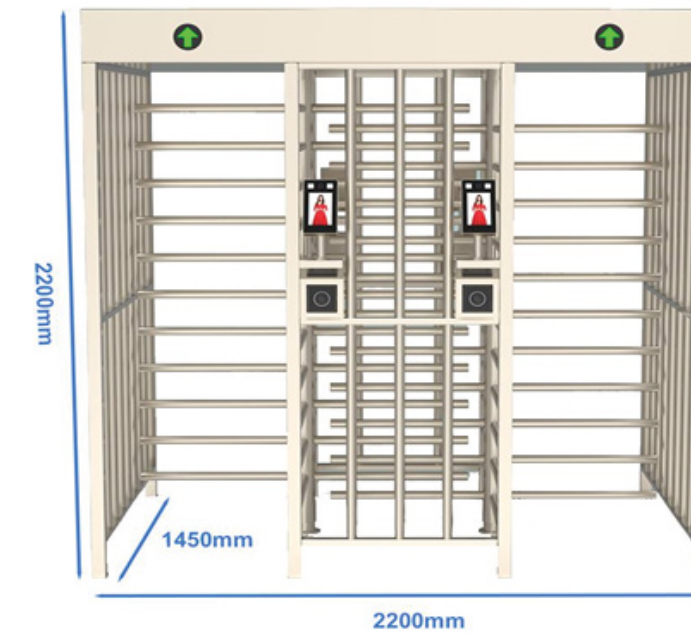

Access control

* RFID reader, Barcode scanner, Facial recognition, Fingerprint reader



Specifications

* Size: 2200x1500x2200mm	* Material: 1.2/1.0mm 304 SUS
* Pass Width: 550mm	* Pass rate: 30-35p/min
* Operating time: 0.2s	* Input: AC100-240V,50/60HZ
* Opening signal: Dry contact	* Working voltage: DC24V
* Mechanism: Pro solenoid lock	* MCBF: 5 million times

FULL HEIGHT TURNSTILE

EN06

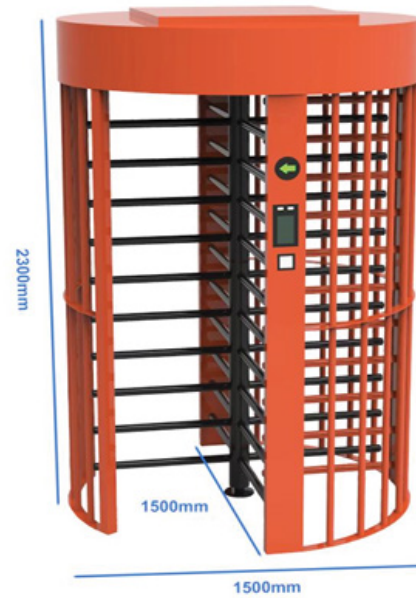

Access control

* RFID reader, Barcode scanner, Facial recognition, Fingerprint reader



Specifications

- | | |
|--------------------------------|-------------------------------|
| * Size: 1500x1500x2300mm | * Material: 1.5/1.2mm 304 SUS |
| * Pass Width: 550mm | * Pass rate: 20-25p/min |
| * Operating time: 0.2s | * Input: AC100-240V,50/60HZ |
| * Opening signal: Dry contact | * Working voltage: DC24V |
| * Mechanism: Pro solenoid lock | * MCBF: 5 million times |

EN09

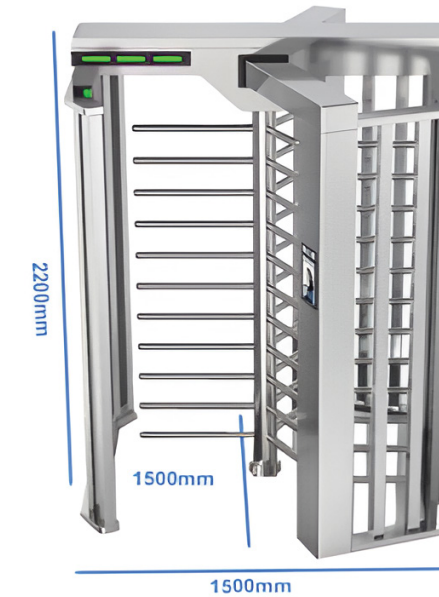

Access control

* RFID reader, Barcode scanner, Facial recognition, Fingerprint reader



Specifications

- | | |
|--------------------------------|-------------------------------|
| * Size: 1500x1500x2200mm | * Material: 1.5/1.2mm 304 SUS |
| * Pass Width: 600mm | * Pass rate: 20-25p/min |
| * Operating time: 0.2s | * Input: AC100-240V,50/60HZ |
| * Opening signal: Dry contact | * Working voltage: DC24V |
| * Mechanism: Pro solenoid lock | * MCBF: 5 million times |

FULL HEIGHT TURNSTILE

EN10

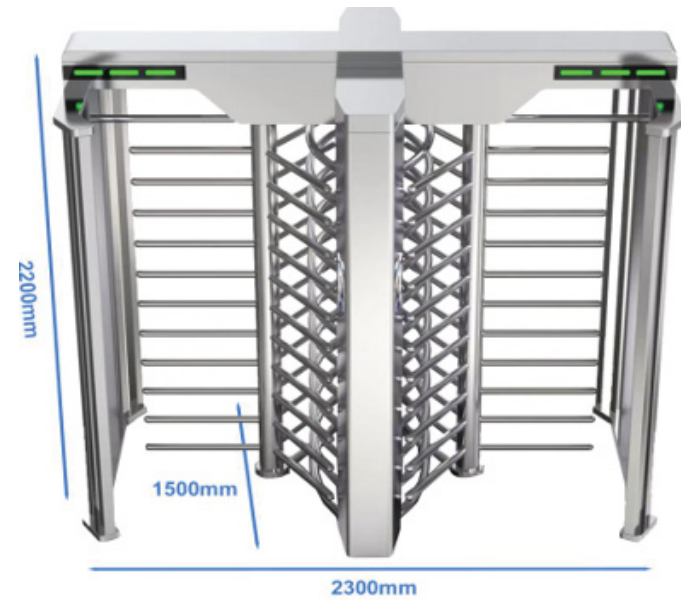

Access control

* RFID reader, Barcode scanner, Facial recognition, Fingerprint reader

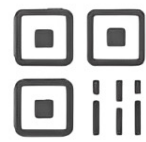

Specifications

* Size: 2200x1500x2200mm	* Material: 1.5/1.2mm 304 SUS
* Pass Width: 600mm	* Pass rate: 20-25p/min
* Operating time: 0.2s	* Input: AC100-240V,50/60HZ
* Opening signal: Dry contact	* Working voltage: DC24V
* Mechanism: Pro solenoid lock	* MCBF: 5 million times

UK & Europe



Head Office
Entrar Access Technologies UK LTD
124 City Road, EC1V 2NX
London, United Kingdom
Call: +44(0)207 566 3939
Company registration in England and Wales: 06294297

Middle East & Africa



Entrar Access Technologies
GBC 2
Opposite to Old Airport Arrival Terminal
C Ring Rd, Doha, Qatar
Call: +97444023014

Entrar Line Trading L.L.C
Smartplace Business Center
Level 2, The Iridium Building
Al Barsha, Dubai - UAE
+971 5080 94464

India & Far East



Entrar Access Technologies India PVT LTD
No A-83, First Floor, Road No 2, Mahipalpur Extn,
New Delhi, Delhi
Call: +918310330566

